

Telescoping Metal Covers, Vertical

Your Company: _____

Address: _____

Contact: _____

Phone: _____ Ext.: _____

Fax: _____

Email: _____

General Waycover Information

Use the drawings on this page to determine your relevant dimensions

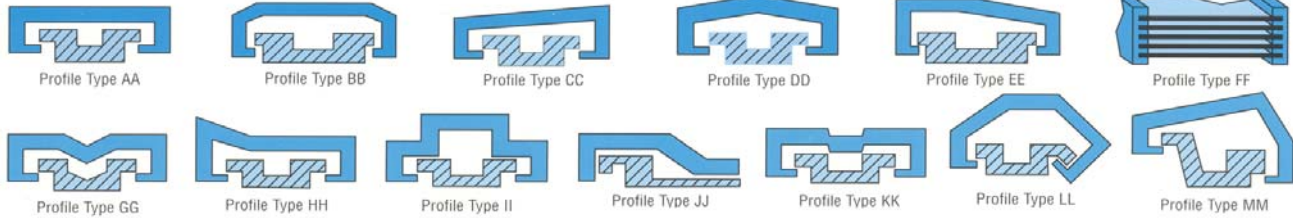

Are the ways hardened?	Yes	No	Profile Type _____	(from diagrams above)
Are the way extensions required	Yes	No	Cover Applications	End Table-Column
Type of linear rails (if applicable)	_____		Quantity Required	_____
Max traverse rate of Slide	_____		Make/Model of machine	_____

A: Extended Length _____

B: Compressed Length _____

C: Travel (Stroke) _____

D: End of Ways to Table _____

E: Table Width _____

F: Top of Way to Top of Table _____

G: Top of Way to Top of Interference _____

H: Interference Above Way _____

I: Width of Interference _____

J: Clearance Below Way _____

K: Side of Way to Side of Interference _____

L: Width Across Ways _____

M: Way Width _____

M1: Way Height _____

M2: Clearance Below Way _____

M3: Way Overhang _____

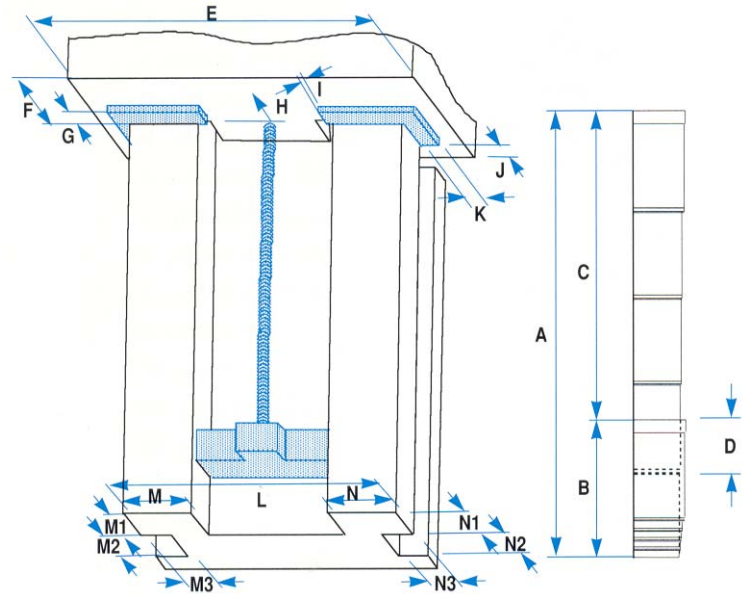

N: Way Width _____

N1: Way Height _____

N2: Clearance Below Way _____

N3: Way Overhang _____