

Stainless Steel Plated Bellows, Horizontal

Your Company: _____
 Contact: _____
 Phone: _____ Ext.: _____
 Fax: _____

Address: _____

 Email: _____

Bellow Dimensions:

Quantity Required _____
 Extended Length _____
 Compressed Length _____
 Travel/Stroke _____

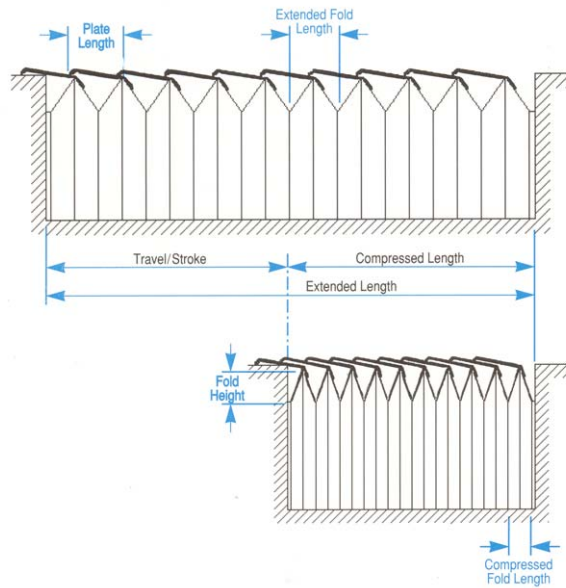

A: Width _____
B1: Height (L) _____
B2: Height (R) _____
C1: Running Surface Height (L) _____
C2: Running Surface Height (R) _____
D1: Running Surface Width (L) _____
D2: Running Surface Width (R) _____

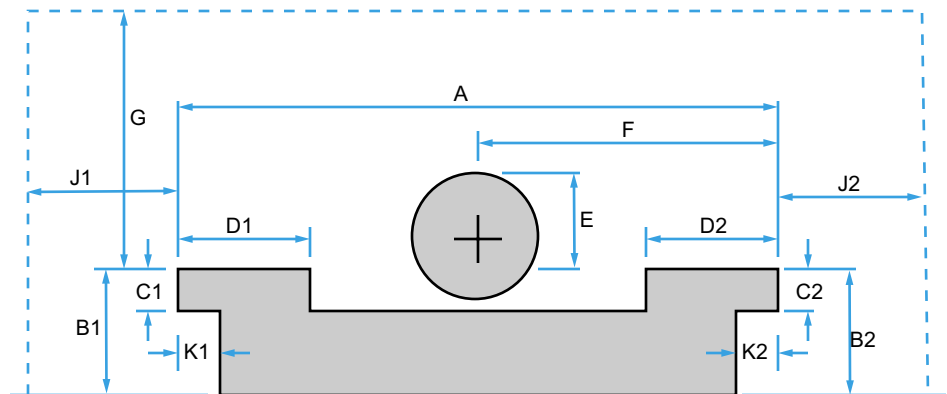

E: Height to Top of Obstruction _____ (if applicable)
F: Edge of Way to Centerline of Obstruction _____ (if applicable)
G: Maximum Clearance Available Over Way _____
J1: Maximum Clearance (L) _____
J2: Maximum Clearance (R) _____
K1: Dimension Under Running Surface (L) _____
K2: Dimension Under Running Surface (R) _____